



# ENDURA TRI-PROOF 20W/40W CCT LED BATTEN

Model No	22371/08	22372/08
Wattage	20W / 40W	20W / 40W

Before first using your new fitting, it is most important that you read and follow these instructions, even if you feel you are quite familiar with this type of product. Retain this document for future reference.

**THIS FITTING MUST BE INSTALLED BY A QUALIFIED ELECTRICAL CONTRACTOR**

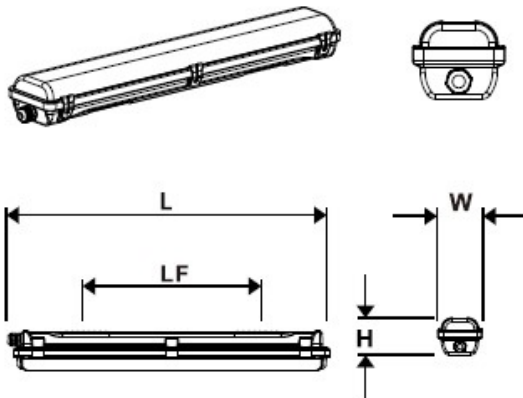

L = 1238mm  
W = 120mm  
H = 76mm  
LF = 800mm

Fig 1

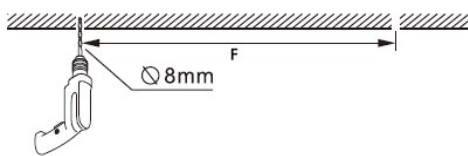

Fig 2



Fig 3

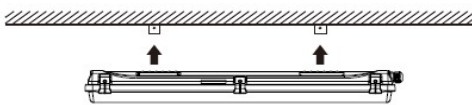
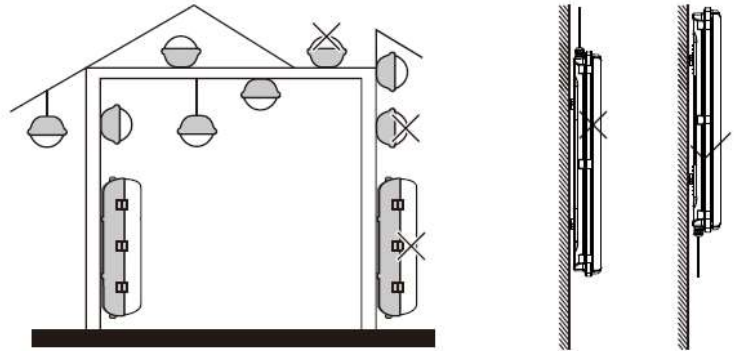
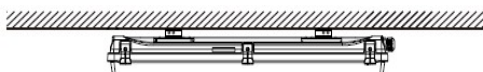

Fig 4



## Mounting Instructions:

1. Drill  $\varnothing$  8mm holes. (Figure 1)
2. According to the fixing hole centre, instal expansion bolts and screws. Install the bracket (Figure 2).
3. Fix the Luminaire with the brackets. (Figure 3).
4. Use screws and suitable fixture system to secure the fitting to the ceiling (Figure 2).
5. Installation finished.

## Warning:

- Installation, repair and/or inspection must be conducted by qualified personnel in accordance with Australian Standards and local Building codes.
- Do not install in a position where the fitting can be easily accessed by children.
- If product is functioning irregularly, please TURN OFF the power and contact the nearest authorized dealer.
- Do not perform unauthorised modification to the light fixture.
- Failure to follow these instructions may result in breakages and will invalidate warranty.



# ENDURA TRI-PROOF 20W/40W CCT LED BATTEN

Model No	22371/08	22372/08
Wattage	20W / 40W	20W / 40W

Fig 5

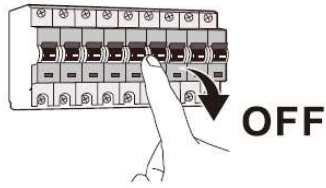

Fig 6



Fig 7

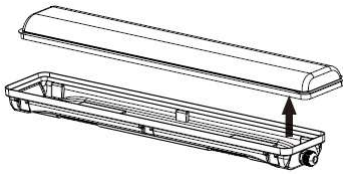

Fig 8

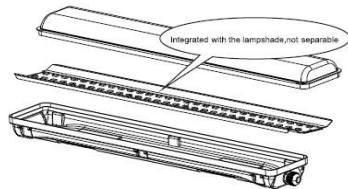

Fig 9

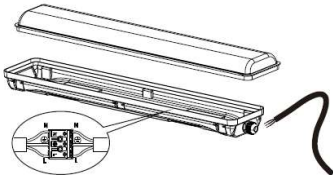

Fig 10

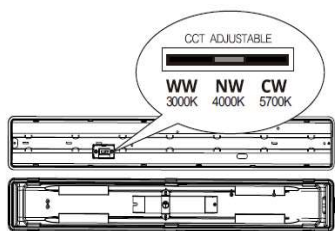

Fig 12

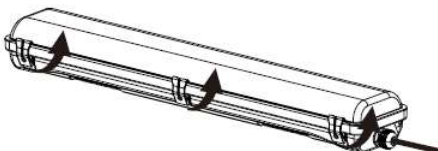
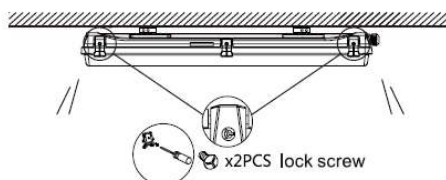

Fig 14



## Installation Instructions:

1. Ensure mains supply is switched OFF. (Fig 5)
2. Gently release the 10 metal clips holding the diffuser. (Fig 6)
3. Lift diffuser from light fitting. (Fig 7)
4. LED Strip is integrated with the diffuser and separable. (Fig 8)
5. Thread the cable through the cable gland. Connect the Live (L), Neutral (N) and Earth according to the markings on the terminal block. (Fig 9)
6. To select a colour temp, slide the CCT switch On the side of the batten to the desired position. (Fig 10)
7. Power setting can be changed between 20W and 40W by changing the Power Switch on side of the LED driver.
8. Refit the Diffuser. (Fig 11)
9. lock in the clamps. (Fig 12)
10. Turn the power ON. (Fig 13)
11. Use two lock screws to secure metal clamps. (Fig 14)

Fig 11

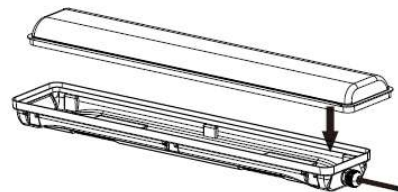

Fig 13





# ENDURA TRI-PROOF 20W/40W CCT LED BATTEN

Model No	22371/08	22372/08
Wattage	20W / 40W	20W / 40W

## MICROWAVE SENSOR SETTING AND PARAMETER – MODEL 22372/08

### Ceiling mounting:

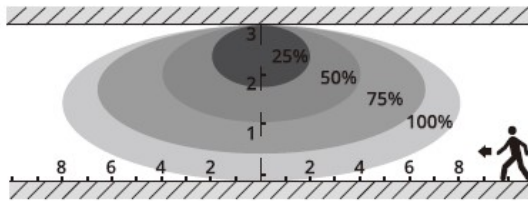

Ceiling mounted height: 3m  
Sensitivity: 100%/75%/50%/25%  
Slow moving speed (Speed: 0.3m/s)  
Max. mounting height: 6m\*

\*At 6m mounting height 25% / 50% sensitivity is not able to detect motion signal.

### Wall mounting:

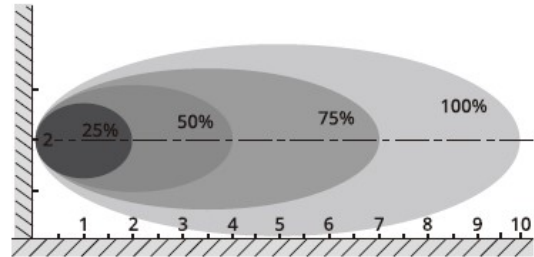

Wall mounted height: 2m  
Sensitivity: 100%/75%/50%/25%  
Slow moving speed (Speed: 0.3m/s)

### DIP Switch settings:



Detection Area    Hold Time    Daylight  
Detectiegebied    Nalooptijd    Daglicht

#### Detection Area

ON		1	2	
ON	ON	ON	ON	100%
OFF	ON	ON	ON	75%
ON	OFF	ON	ON	50%
OFF	OFF	ON	ON	25%

#### Hold Time

ON			3	4	5	
ON	ON	ON	ON	ON	ON	5s
OFF	ON	ON	ON	ON	ON	30s
ON	OFF	ON	ON	ON	ON	90s
OFF	OFF	ON	ON	ON	ON	5min
ON	ON	OFF	ON	ON	ON	20min
OFF	OFF	OFF	ON	ON	ON	30min

#### Daylight Function

ON			6	7	8	
ON	ON	ON	ON	ON	ON	2lux
ON	ON	OFF	ON	ON	ON	10lux
OFF	ON	OFF	ON	ON	ON	30lux
ON	OFF	OFF	ON	ON	ON	50lux
OFF	OFF	OFF	ON	ON	ON	Disable

### Warning:

- Installation, maintenance and inspection for safety concerns should be done by a qualified electrician.
- Power should be cut off before installation, maintenance or inspection.
- Please install and use the product strictly according to the instructions.
- Do not Disassemble or remould the product to avoid electrical shock or to cause failure of the light.
- Working out of temperature range of -20° C to +40° C will shorten the lifetime of the product.



# ENDURA TRI-PROOF 20W/40W CCT LED BATTEN

Model No	22371/08	22372/08
Wattage	20W / 40W	20W / 40W

## Specifications:

**Fitting:** PC Body, PC Diffuser

**Protection:** Class I, IP66

**Ratings:** 220VAC to 240VAC, 50Hz, 20W/40W

**Light Source:** LED (Non-Replaceable)

**Lumens:** 4000lm

**CCT:** 3000K | 4100K | 6000K

**Dimming:** Not Dimmable

## Warranty:

Brilliant Lighting warrants this product against defects in manufacture and workmanship for a period of 3 years from date of purchase or as specified on the packaging. For products used in non-domestic or commercial applications, Brilliant Lighting warrants this product for a period of 3 months from date of purchase. This warranty is only valid for products installed by a qualified electrical contractor and operated within the guidelines specified by Brilliant Lighting, and within the correct operating voltage ranges as stated on the product's rating label.

Warranty does not include damage or loss arising from incorrect installation, operation or maintenance of this product, damage caused through modification, incorrect installation, service by unqualified or unauthorised personnel or lack of regular maintenance and cleaning. Proof of installation by qualified personnel may be required, eg. Electrical Safety Certificate. Proof of purchase must be supplied with all warranty claims.

This warranty is provided in addition to any other rights and remedies of the customer under any law. In applications not intended for household, personal or domestic use, liability is limited to replacement or reimbursement of product only. Brilliant Lighting does not warranty the costs of removal or re-installation of this product or associated components.

*Our goods come with guarantees that cannot be excluded under the Australian Consumer Law. You are entitled to a replacement or refund for a major failure and compensation for any other reasonably foreseeable loss or damage. You are also entitled to have the goods repaired or replaced if goods fail to be of acceptable quality and the failure does not amount to a major failure.*

Any claim under this warranty must be made within 2 years of the date of purchase of the product or as specified on the packaging. To make a claim under the warranty; at your own expense take the product (with proof of purchase – receipt or similar) to the store where you purchased the product or contact Brilliant Lighting at the address below.

This warranty is given by:

**Brilliant Lighting (Aust) Pty. Ltd.**

**ABN 37 006 203 694**

**956 Stud Road Rowville, VIC 3178**

**Phone: 03 9765 2555**

**Email: [warranty@brilliantlighting.com.au](mailto:warranty@brilliantlighting.com.au)**

**Made in China**